



CORNELL PUMP COMPANY  
**N SERIES PUMPS**  
FOR SOLIDS HANDLING



**EFFICIENT BY DESIGN**



# CORNELL PUMP COMPANY



Cornell Pump was founded in 1946 by five friends who set out to design a more reliable, durable and efficient pump. Over the years, Cornell engineers have contributed significantly to industry advances in centrifugal pump design with pump features like Cornell Redi-Prime®, Run-Dry™, and Cycloseal® systems.

## CORNELL: WHAT SETS OUR SOLIDS HANDLING LINE APART

Cornell Pump has been producing robust, highly efficient pumps since 1946 and our innovative pump concepts have provided unmatched value. Cornell clear liquid, solids handling, and grit/slurry pumps provide the reliability and interchangeability demanded in many applications. Cornell offers a wide range of pump models and configurations to fit into existing installations. We'll also work with you to create a custom system to satisfy your needs.

Our technical and engineering staff is the best in the business at providing quality solutions.

### A WIDE VARIETY OF SIZES AND CONFIGURATIONS

Models range in size from 1" to 30" and a range of configuration options are available for each model – including frame and engine mount options and Cornell features like Run-Dry™ and Redi-Prime®.

### PUMPS DESIGNED FOR SPECIFIC JOBS

Our team of expert engineers design pumps to meet the varying demands of industry applications, such as solids handling, slurry, and head requirements.

### OUTSTANDING EFFICIENCIES

We put our experience and knowledge to work to produce tested designs with some of the highest efficiencies of any pumps on the market.

### ROBUST CONSTRUCTION

Cornell pumps are built using superior materials selected for their suitability to each pump's intended application. Heavier casting walls, thicker shafts, and fully-machined impellers are part of what make Cornell pumps more rugged and durable than other pumps.

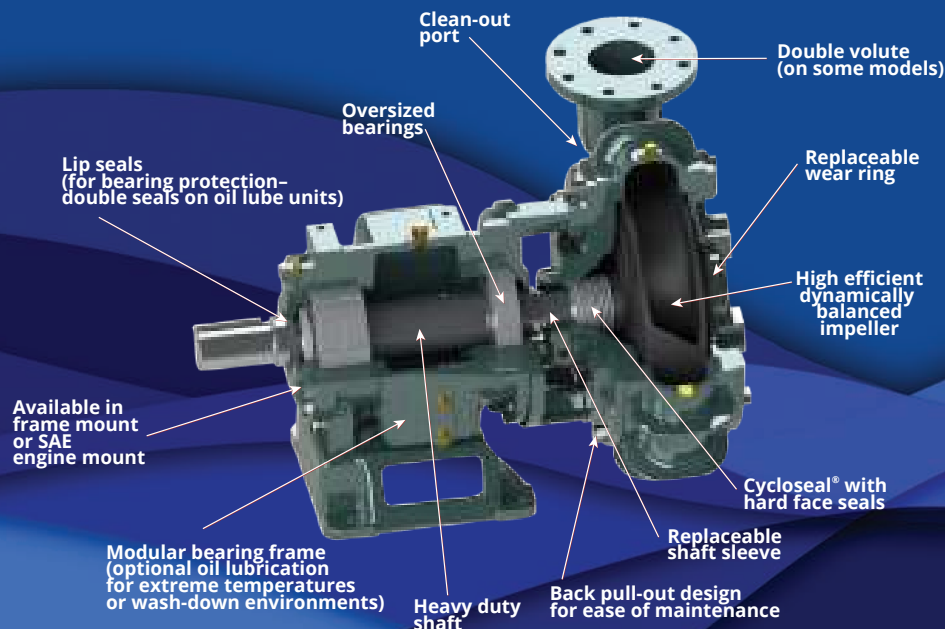

# N SERIES PUMPS

BETTER FEATURES, MORE BENEFITS:

## CORNELL SOLIDS HANDLING PUMPS



### N SERIES PUMPS

Cornell has produced solids handling pumps since the 1950's. Cornell offers a wide range of solids handling pumps, from 3" through 30" discharge size, to handle the most difficult solids applications.

The N series fill the need of medium-duty solids handling capabilities, with efficiencies up to 82%, solids handling sizes of up to 10.2", and flows up to 38,000 GPM. Cornell's N series pumps can be found in a wide range of applications in the Municipal, Agricultural, and Industrial markets; and are available in a variety of mounting configurations including close-coupled, SAE engine mount, horizontal, and vertical mounted.

### CHOPPERS & CUTTERS

Chopper impellers (4NC/6NC) and cutter assemblies expand the capabilities of N-series pumps to handle difficult solids. Many N series pumps are also available in CD4MCu for resistance to corrosion and pitting caused by abrasive solids.

### SP & MP SERIES PUMPS

The Cornell SP & MP series pumps are also designed for solids handling and offer greater wear resistance at higher operating pressures, ideal for the worst slurry and sludge in mining and agricultural applications.



## BUILT TO LAST

Cornell N and T Series pumps are designed and built to superior standards to withstand the most demanding applications. Cornell pumps offer excellent hydraulic efficiencies, low maintenance and operating costs, and are backed by a two-year warranty.

- REPLACEABLE WEAR PARTS INCLUDING WEAR RINGS AND SHAFT SLEEVES
- DYNAMICALLY-BALANCED IMPELLERS
- OVERSIZED BEARINGS WITH MIN. 20,000 HOUR LIFE
- VARIOUS MATERIALS OF CONSTRUCTION FOR ABRASIVE OR HARD TO HANDLE SOLIDS
- HIGH SUCTION LIFT
- HEAVY WALLED CASTINGS FOR DURABILITY
- DOUBLE VOLUTES FOR BALANCING INTERNAL PRESSURES
- LOW SHAFT DEFLECTION
- PATENTED CYCLOSEAL DESIGN (#5489187)
- NO SEAL FLUSH NEEDED



# PUMP PERFORMANCE

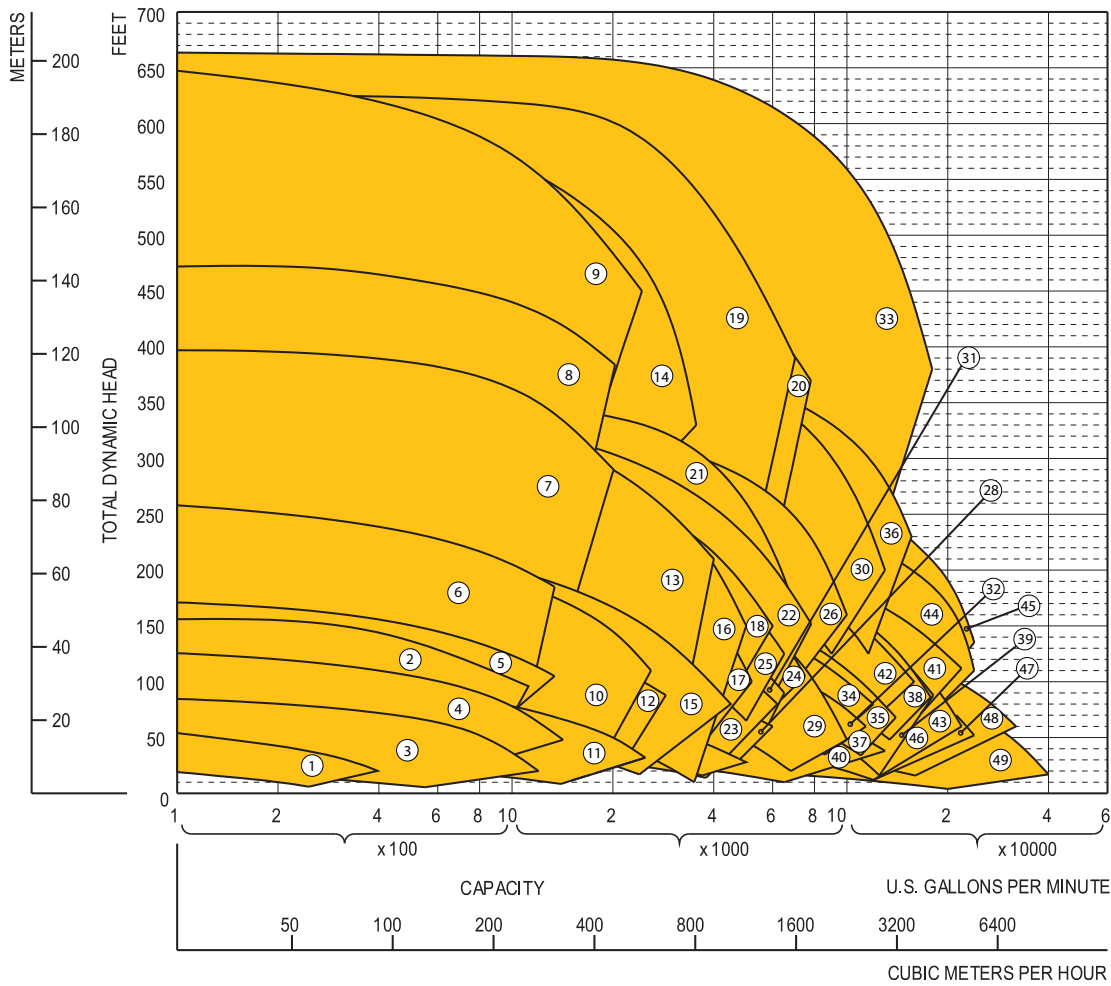

- |             |             |
|-------------|-------------|
| 1. 3NLT     | 32. 14NHG   |
| 2. 3NNTL    | 33. 14NHG34 |
| 3. 4NNTL    | 34. 14NHGA  |
| 4. 4NNT     | 35. 14NHGH  |
| 5. 4NHTA    | 36. 14NHG28 |
| 6. 4414T    | 37. 16NHGH  |
| 7. 4514T    | 38. 16NHG22 |
| 8. 4NHTB    | 39. 16NHG26 |
| 9. 4NHTB19  | 40. 16NHT32 |
| 10. 6NHTA   | 41. 18NHG   |
| 11. 6NNT/TL | 42. 18NHG22 |
| 12. 6NHT/TH | 43. 18NHFL  |
| 13. 6NHTB   | 44. 18NHF34 |
| 14. 6NHTB19 | 45. 18NHG34 |
| 15. 8NNT/TL | 46. 20NHFL  |
| 16. 8NHTA   | 47. 20NHF   |
| 17. 8NHTH   | 48. 24NNG   |
| 18. 8NHTR   | 49. 30NNT   |
| 19. 8NHG19  |             |
| 20. 8NHG22  |             |
| 21. 8NHGA   |             |
| 22. 10NNT   |             |
| 23. 10NHTB  |             |
| 24. 10NHTBH |             |
| 25. 10NHTA  |             |
| 26. 12NHTB  |             |
| 27. 12NHTL  |             |
| 28. 12NHTM  |             |
| 29. 12NNT   |             |
| 30. 12NHG28 |             |
| 31. 12NNT   |             |

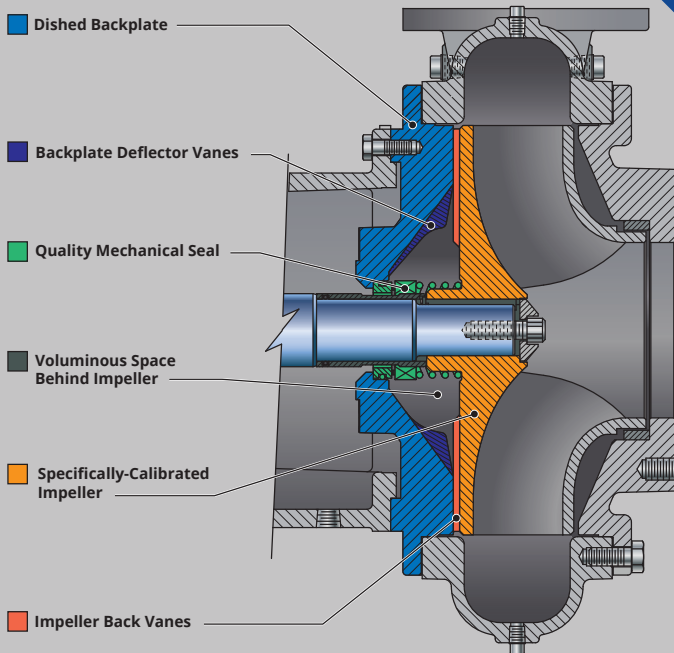

## CYCLOSEAL® SYSTEM FOR GRIT REMOVAL

Cycloseal® is a patented system with a self-contained single mechanical seal with a dished line. The Cycloseal pattern cast into the pump backplate in conjunction with contoured impeller back vanes and a dished backplate creates pressure gradients that move solids and entrained vapor away from the seal faces. The Cycloseal system is only available on Cornell pumps.

- Removes grit from pump seal compartment
- Extends pump seal life three times standard mechanical
- No drips/mess at application site
- Reduced maintenance costs
- Increased uptime and reliability

# SOLIDS HANDLING IMPELLERS



## ENCLOSED TWO, THREE, AND FOUR PORT SPHERICAL SOLIDS

Large spherical solids pass through the pump while offering optimal head and efficiency.

- 2" or larger solids
- 3" to 30" discharge sizes
- Flows to 40,000 GPM and heads to 450'



## THREE OR FOUR BLADED, SEMI-OPEN SLURRY

Cutting action allows the semi-open impeller to handle the worst slurries at high heads.

- 1" or larger soft solids
- 1.25" to 10" discharge size



## DELTA STYLE

### STRAW AND STRINGY MATERIALS

Trailing edges on impeller vanes reduce low pressure areas. Vortices are created which pass solids through the impeller. No "hair pinning" or hang-up of stringy materials. Larger solids are broken up.

- For difficult solids
- 3" to 10" discharge size
- Flows to 5000 GPM and heads to 400'



## CHOPPER

### WASTE MATERIALS

Available on the 4NC and 4NC units, Cornell's Chopper impeller is ideally suited for chopping solids. Featuring heat-treated cast steel, the impeller easily chops solids up to 2" continuously.

- 2" or smaller solids
- Low flows possible
- heads to 380'



## BLADE CUTTER

### RAGGING MATERIALS

Rotating and stationary cutter blades mounted on the suction end break up clogs and rags before they reach the impeller while keeping efficiencies as high as possible.

- Minimal energy consumption (4% or less)
- Hardened, adjustable cutter blades
- Minimize flow restrictions

## WASTE WARRIOR CUTTER

### SEVERE RAGGING

A more aggressive solution to troublesome clogs and severe ragging issues. A scythe-like edge sweeps the area where the suction pipe meets the volute to keep materials from clogging in the impeller area.

- Limited energy consumption (around 8%)
- Hardened cutter blades
- Insignificant flow restrictions



# CORNELL FEATURES & BENEFITS

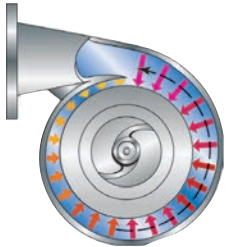

Single Volute

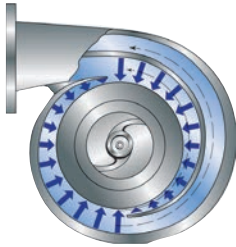

Double Volute

## DOUBLE VOLUTE DESIGN

Cornell's double volute system minimizes radial thrust loads common with high capacity, high-head centrifugal pumps, by balancing the radial forces around the impeller.

- Minimizes radial thrust load
- Eliminates shaft flexing and fatigue
- Greatly extends life of packing/seal, wear rings and bearings
- Effectively meets high pressure and high volume requirements

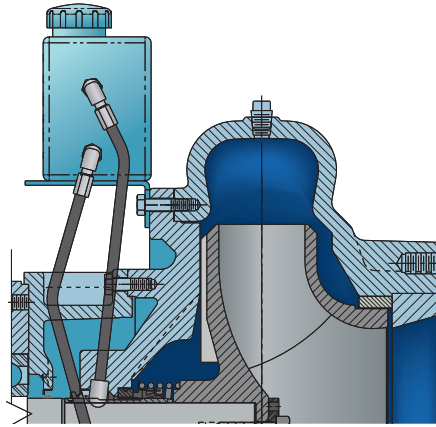

## RUN-DRY™ SEAL PROTECTION

Cornell's Run-Dry system consists of an auxiliary gland and oil reservoir that keeps the seal faces lubricated and prevents dry running of the seal faces during priming, re-priming, or standby operation.

- Run dry for hours without damaging the seal
- Cools and lubricates seal faces
- Ideal for applications that could operate in a dry condition
- Useable in conjunction with Cyclo Seal® and Redi-Prime®

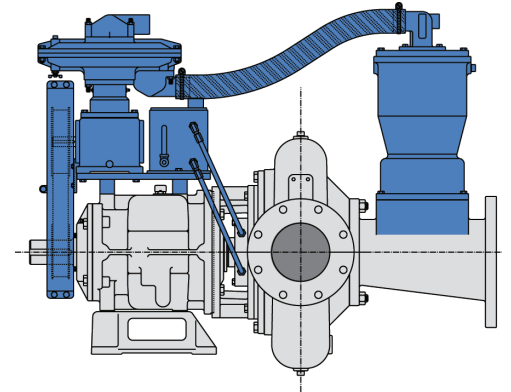

## REDI-PRIME® DRY-PRIMING OPTION

Cornell Redi-Prime pumps are designed with oversized suctions to provide more flow, reduced friction losses, and higher suction lift. The priming system was designed with the environment in mind. By using a positive sealing float box and a diaphragm vacuum pump, there is no water carry-over to contaminate the environment. Redi-Prime is offered on all Cornell industrial pumps, and is available in virtually every other pump we design as well.

- Fully automatic priming and repriming
- Handles air/liquid mixtures with ease
- Rapidly primes and re-primers completely unattended
- Environmentally safe priming system designed to prevent product leakage
- Handles large sized solids
- High suction lift capability up to 28'
- Premium hydraulic efficiency for reduced energy consumption

## CD4MCu OPTIONS

CD4MCu is a duplex stainless steel, with greater corrosive resistance than standard stainless steel. CD4MCu allows the pumps to be used in more abrasive applications, and it won't pit like regular stainless steel, has a better stress/corrosive cracking resistance than standard stainless, and higher strength than standard stainless steel. And compared with regular cast iron material, it is much more resistant to corrosion and much stronger.

Most of our dealers have access to 11 of Cornell's most popular models in CD4MCu, allowing us to slash production time and price. Cornell can supply a CD4MCu pump in as little as one to two weeks.

- Clean Steel
- Usable in PH levels of 2 to 13.5
- Brinell hardness up to 275
- Corrosion and pitting resistance
- Higher strength than standard stainless steel
- Improved ductility and weldability
- Better resistance to embrittlement

# N SERIES PUMPS

## SOLIDS HANDLING PUMP MODELS

MODEL	DISCHARGE SIZE	IMPELLER DIA.	MAX CAPACITY	MAX SOLIDS	MAX HEAD	RPM
3NLT	3"	6.50"	400 GPM	2.00"	54'	2000
3NNTL	3"	8.25"	1100 GPM	2.00"	155'	2500
4414T	4"	14.00"	1600 GPM	3.00"	430'	2300
4514T	4"	14.00"	1950 GPM	3.00"	395'	2300
4NHTA	4"	12.00"	1400 GPM	3.00"	225'	2000
4NHTB	4"	17.50"	1800 GPM	3.00"	470'	2000
4NHTB19	4"	19.50"	2400 GPM	2.00"	650'	2100
4NNT	4"	10.09"	1400 GPM	3.00"	150'	2000
4NNTL	4"	8.25"	1450 GPM	3.00"	165'	2500
6NHT	6"	14.09"	2650 GPM	4.00"	100'	1200
6NHTA	6"	14.00"	2800 GPM	3.00"	295'	2000
6NHTB	6"	17.50"	4250 GPM	3.38"	400'	1900
6NHTB19	6"	19.50"	3500 GPM	2.00"	520'	2100
6NHTH	6"	14.00"	2600 GPM	4.00"	170'	1500
6NNT	6"	10.09"	2700 GPM	3.00"	150'	2100
6NNTL	6"	8.25"	2250 GPM	3.00"	125'	2400
8NHG19	8"	19.50"	6500 GPM	2.44"	625'	2150
8NHG22	8"	21.95"	7800 GPM	3.00"	615'	1770
8NHGA	8"	17.50"	7000 GPM	4.00"	360'	1800
8NHTA	8"	17.50"	5000 GPM	3.38"	400'	1900
8NHTH	8"	21.95"	7500 GPM	4.00"	460'	1800
8NHTR	8"	16.44"	5700 GPM	5.00"	310'	1800
8NNT	8"	14.00"	4500 GPM	3.38"	255'	1900
8NNTL	8"	11.75"	3800 GPM	2.88"	145'	1800
10NHTA	10"	21.88"	6400 GPM	4.25"	245'	1200
10NHTB	10"	19.50"	8000 GPM	4.75"	195'	1200

MODEL	DISCHARGE SIZE	IMPELLER DIA.	MAX CAPACITY	MAX SOLIDS	MAX HEAD	RPM
10NHTBH	10"	21.88"	7300 GPM	4.75"	255'	1200
10NNT	10"	17.50"	7700 GPM	3.38"	355'	1800
12NHG28	12"	28.00"	12000 GPM	3.20"	410'	1200
12NHTB	12"	19.50"	7800 GPM	4.75"	175'	1200
12NHTL	12"	14.00"	5200 GPM	4.25"	140'	1500
12NHTM	12"	17.50"	5600 GPM	4.25"	140'	1200
12NNF	12"	14.00"	8500 GPM	3.00"	195'	1800
12NNT	12"	14.00"	6000 GPM	4.00"	225'	1900
14NHG	14"	17.50"	12000 GPM	4.00"	210'	1500
14NHG28	14"	28.00"	15000 GPM	4.25"	420'	1200
14NHG34	14"	34.00"	18000 GPM	4.25"	660'	1200
14NHGA	14"	19.50"	11000 GPM	4.00"	165'	1200
14NHGH	14"	19.50"	13500 GPM	4.25"	180'	1200
16NHG22	16"	21.95"	16500 GPM	4.50"	265'	1200
16NHG26	16"	26.00"	18000 GPM	4.50"	170'	700
16NHGH	16"	19.50"	13500 GPM	4.25"	175'	1200
16NHT32	16"	32.00"	20500 GPM	6.40"	200'	900
18NHG34	18"	32.00"	17000 GPM	4.50"	320'	900
18NHFL	18"	26.50"	23000 GPM	5.00"	190'	890
18NHG	18"	28.00"	20000 GPM	5.00"	220'	900
18NHG22	18"	21.95"	15000 GPM	4.50"	205'	1200
18NHG34	18"	34.00"	24000 GPM	4.50"	320'	900
20NHG	20"	28.00"	24000 GPM	5.00"	135'	750
20NHFL	20"	25.50"	24000 GPM	5.00"	190'	990
24NNG	24"	28.00"	32000 GPM	5.25"	135'	750
30NNT	30"	34.19"	38000 GPM	10.20"	105'	585

## CORNELL SOLIDS HANDLING PUMP MODEL DESIGNATIONS

example: 6NHTA

DISCHARGE SIZE (IN INCHES)	PUMP SERIES (NN OR NH)	IMPELLER TYPE
6	NH	TA

### IMPELLER TYPES IN MODEL DESIGNATIONS:

T: 2 port, enclosed	TR: 2 port enclosed, hybrid	DH: Delta high head, vortex
TA: 2 port enclosed, initial version	G: 3 port enclosed	HM: Semi-open
TB: 2 port enclosed, high head	F: 4 port enclosed	P/PP: Single port, enclosed
TL: 2 port enclosed, low Head	DL: Delta low head, vortex	C: Chopper

### ALTERNATE DESIGNATIONS:

example: 4414T

DISCHARGE SIZE (IN INCHES)	SUCTION SIZE (IN INCHES)	MAX. IMPELLER DIA.	IMPELLER TYPE
4	4	14	T



# MARKET AND PRODUCT LINE



AGRICULTURAL



FOOD PROCESS



INDUSTRIAL



MINE DEWATERING



MUNICIPAL



REFRIGERATION



OIL & GAS



CYCLOSEAL®



CHOPPER



CUTTER



EDGE™



HYDRAULIC SUBS



HYDRO TURBINE



IMMERSIBLE



MANURE



MP SERIES



MX SERIES



MX MINING

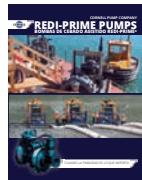

REDI-PRIME®

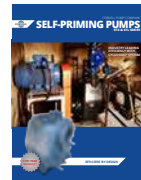

SELF PRIMING



SLURRY



SUBMERSIBLE



WATER TRANSFER



V SERIES

Cycloseal® and Redi-Prime® are Registered Trademarks of Cornell Pump Company.

Cornell pumps and products are the subject of one or more of the following U.S. and foreign patents: 3,207,485; 3,282,226; 3,295,456; 3,301,191; 3,630,637; 3,663,117; 3,743,437; 4,335,886; 4,523,900; 5,489,187; 5,591,001; 6,074,554; 6,036,434; 6,079,958; 6,309,169; 2,320,742; 96/8140; 319,837; 918,534; 1,224,969; 2,232,735; 701,979 and are the subject of pending U.S. and foreign patent applications.

**CORNELLPUMP.COM**  
©2015 CORNELL PUMP COMPANY



Cornell Pump Company  
Clackamas, Oregon, USA  
P: +1 (503) 653-0330  
F: +1 (503) 653-0338

AUTHORIZED CORNELL PUMP DISTRIBUTOR